

Detail A

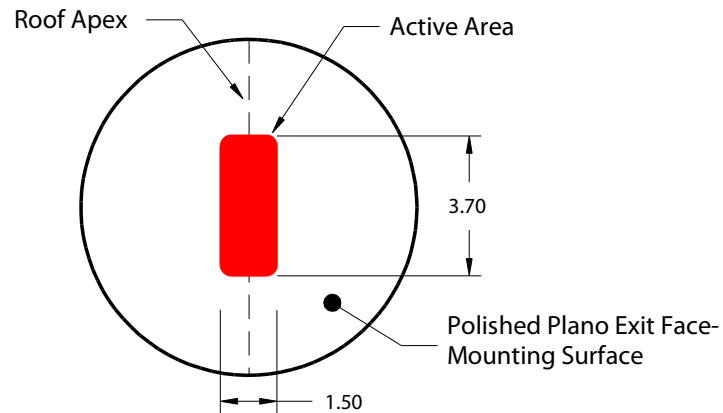
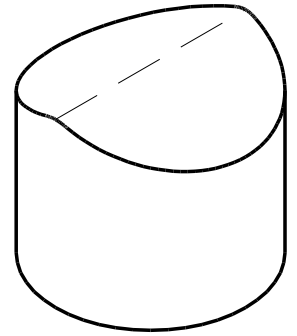
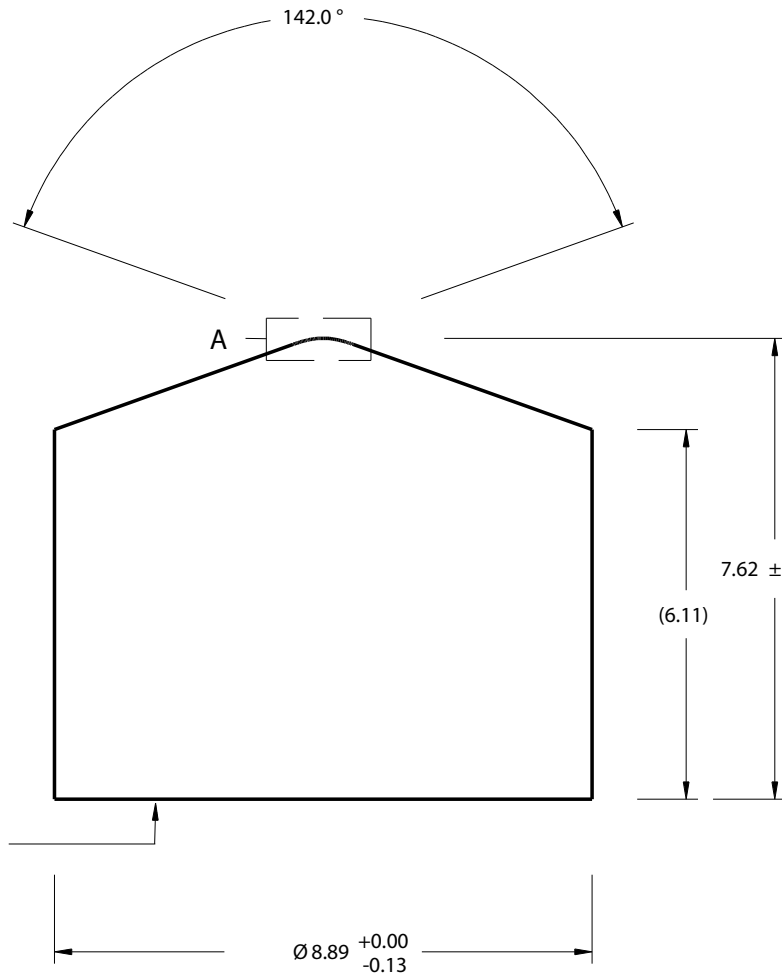

Fan angle: $20^\circ \pm 3\%$
 Beam Size(1): 1
 Line uniformity(2): $<30\%$ total variation
 Contained power(2): $80\% \pm 5\%$
 Bore site: <4 mrad
 Line straightness(2): $<0.1\%$
 Substrate(3): BK7 or equivalent (RoHS Compliant)
 Coating: None
 Performance specifications assume lens matched to laser/collimator

(1) Based on $1/e^2$
 (2) Measured over central 80% of line length
 (3) RoHS Directive 2002/95/EC Compliant
 All dimensions in millimeters
 Specifications subject to change without notice

LASERLINE OPTICS CANADA INC.
 1 - 93 Hines Rd.
 Kanata, Ontario K2K 2M5
 (613) 592 - 2373 - laserlineoptics.com

Scale: 8:1

05/04/2012

Project: Laserline Optics Canada Powell Lenses

20° narrow beam Powell lens

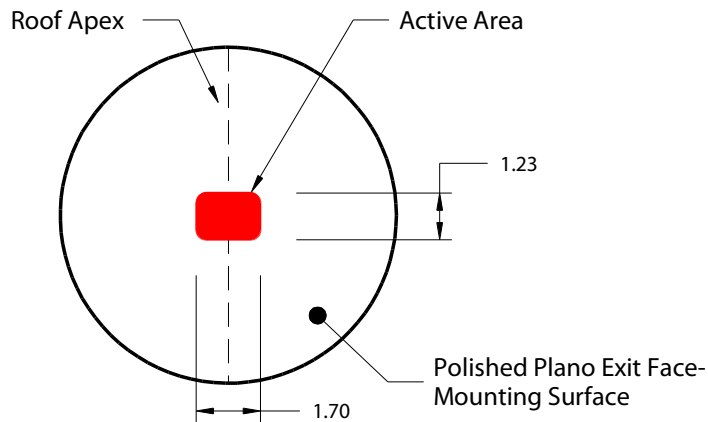
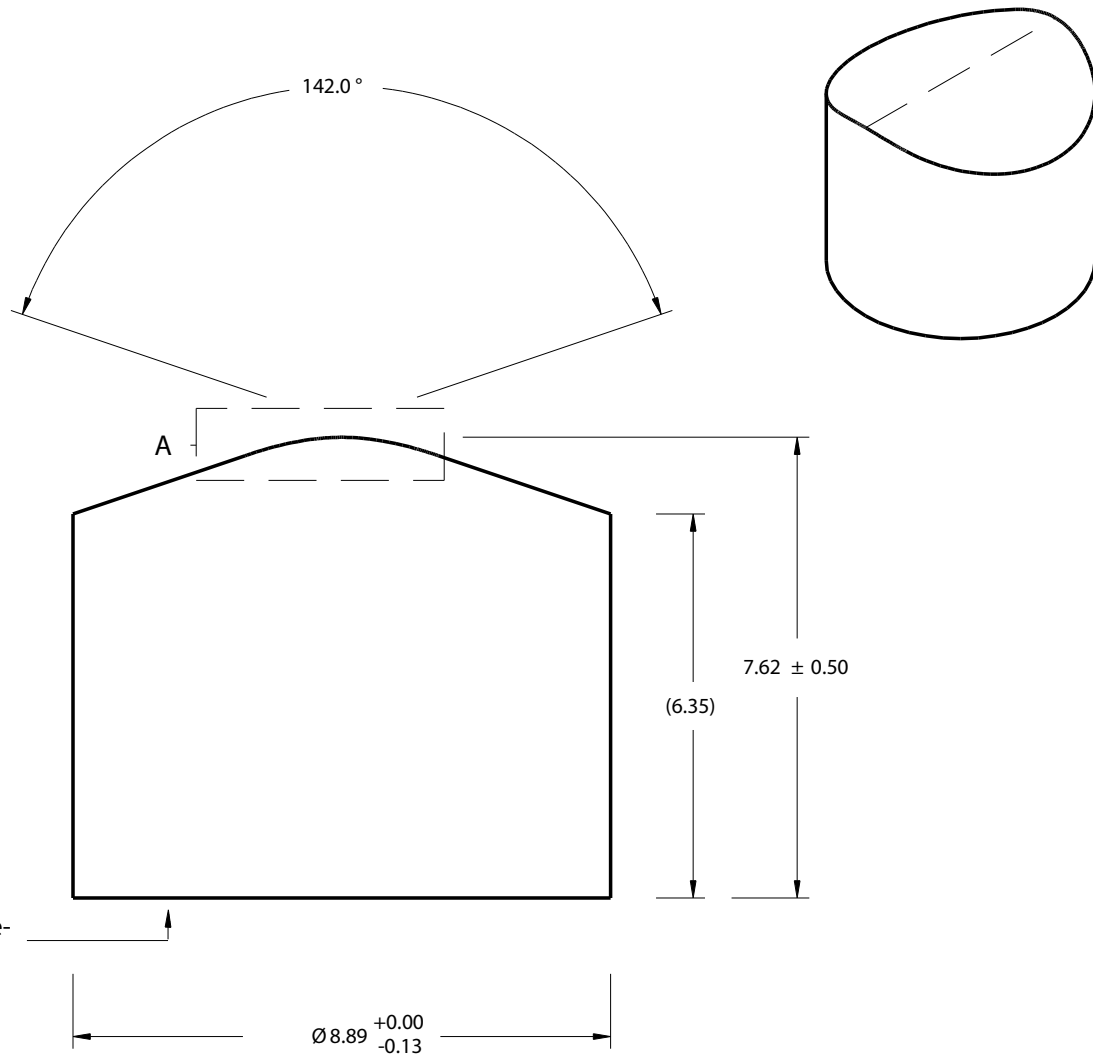
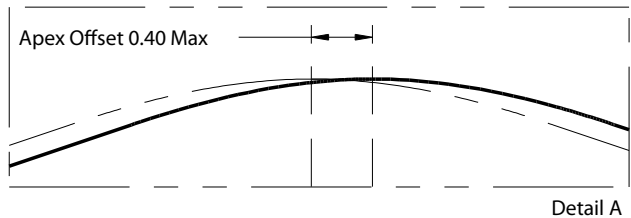

Fan angle: $20^\circ \pm 3\%$
 Beam Size(1): 3.8
 Line uniformity(2): <30% total variation
 Contained power(2): $80\% \pm 5\%$
 Bore site: <4 mrad
 Line straightness(2): <0.1%
 Substrate(3): BK7 or equivalent (RoHS Compliant)
 Coating: None
 Performance specifications assume lens matched to laser/collimator

(1) Based on $1/e^2$
 (2) Measured over central 80% of line length
 (3) RoHS Directive 2002/95/EC Compliant
 All dimensions in millimeters
 Specifications subject to change without notice

LASERLINE OPTICS CANADA INC.
 1 - 93 Hines Rd.
 Kanata, Ontario K2K 2M5
 (613) 592 - 2373 - laserlineoptics.com

Scale: 8:1

Project: Laserline Optics Canada Powell Lenses

05/04/2012

20° wide beam Powell lens